

autovictor

 *Keep on moving to the future.*

MANUALE TECNICO ORMIG 45 TM

TECHNICAL FEATURES

| | |
|------------------------------|---|
| CARRIER: | 4 x 2 x 2 |
| Frame: | Monolithic structure formed by two frame side members fabricated from bended plate at "C" shape and box-type, connected by means of crosspieces in the front and rear part corresponding to the axles location. |
| Engine: | Diesel IVECO NEF F4AE0684C*D, turbo, 6 cylinders, 4 strokes, displacement 5880 cm ³ , power 169 kW (230 HP) at 2300 rpm, max torque 810 Nm at 1250 rpm EUROMOT phase II Water cooling. Fuel tank capacity 300 litres. |
| Speed gearbox: | Trasmission with CLARK torque converter, 4 forward and 4 reverse speeds. Torque conversion ratio: 2,130:1 |
| Axles: | 4 x 2 Driving front axle with rigid suspension. Steering rear axle, central oscillation with limit switches is provided. |
| Tyres: | 16.00-25 32PR standard type, twin tyres in the front axle and single in the rear axle. |
| Steering: | Hydraulic steering, DANFOSS system, controlling two cylinders connected to the cylinders levers. Outer turning circle radius 6,7 m. |
| Brakes: | In compliance with EEC regulations for road travel, drum air control in the front axle and in the rear axle. Two independent circuits. Mechanical parking brake, spring-type, acting to the first axle wheels; control by pneumatic hand distributor. |
| Cab: | Steel structure. Wide visibility for the operator is provided. It is complete with rearview mirrors, instrumentation, windshield wipers, heater, adjustable anatomical seat. The various mouvements are controlled by levers equipped with electrical device against unforeseen operations. |
| Electrical sistem: | 24 V 1680 W alternator Starting motor 2 batteries of 12 V - 143 Ah |
| Boom: | Fabricated from box-type plate at high strength. It is connected to the frame by means of rear gantry. Telescopic boom with a base section and two extensions at proportional hydraulic extraction control. Derricking is provided through two double action cylinders. |
| Winch: | Oleodynamic with automatic brake. Adjustable speed from 0 up to 130 m/min with 4500 daN capacity (5625 daN with 25% overload) at 5th layer single rope. Max. rope lenght 142 m, dia. 16 mm, drum dia. 400 mm |
| Hydraulic system: | Fed by 3 pumps having 300 l/min max delivery. The pumps allow the mouvements to be performed simultaneously. Braking and locking valves in the boom and extensions cylinders. Calibrated valves in the distributors of the hydraulic system. Hydraulic oil tank capacity 450 litres. |
| Safety regulations: | The crane is complete with all safety devices according to the regulations in force and with D.P.R. 547 of 27 May 1955 and subsequent provisions. It is projected in class B3 as per DIN 15018-1. The crane complies with safety and health regulations according to Encl. I of Machine Directive 89/392 and subsequent provisions. Therefore, mark "CE" is on the crane equipped with electronic safe load device. |
| Weight on road: | Total weight 28000 kg |
| Optionals on request: | <ul style="list-style-type: none">• Electronic safe load device• Various lengths special fly jibs• Fix hook at boom top• Self-levelling forks complete with sideshift device• Spare wheel• Special pliers for various performance |

**DIMENSIONI GENERALI - GENERAL DIMENSIONS
DIMENSIONS GENERALES**

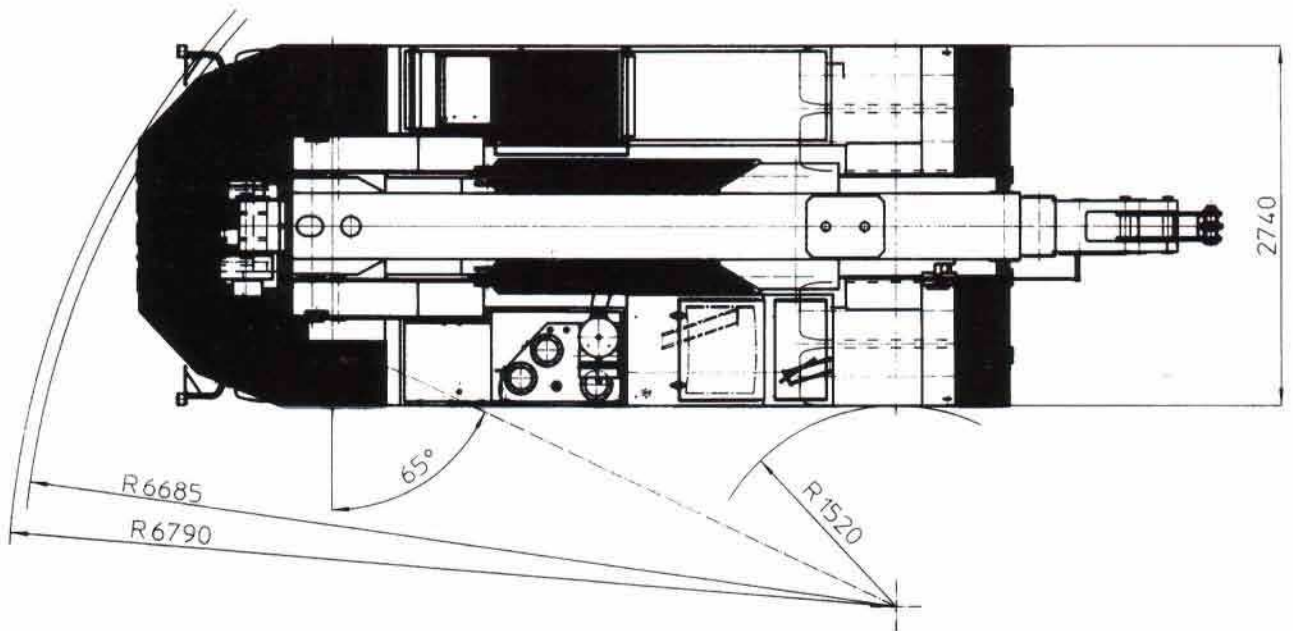
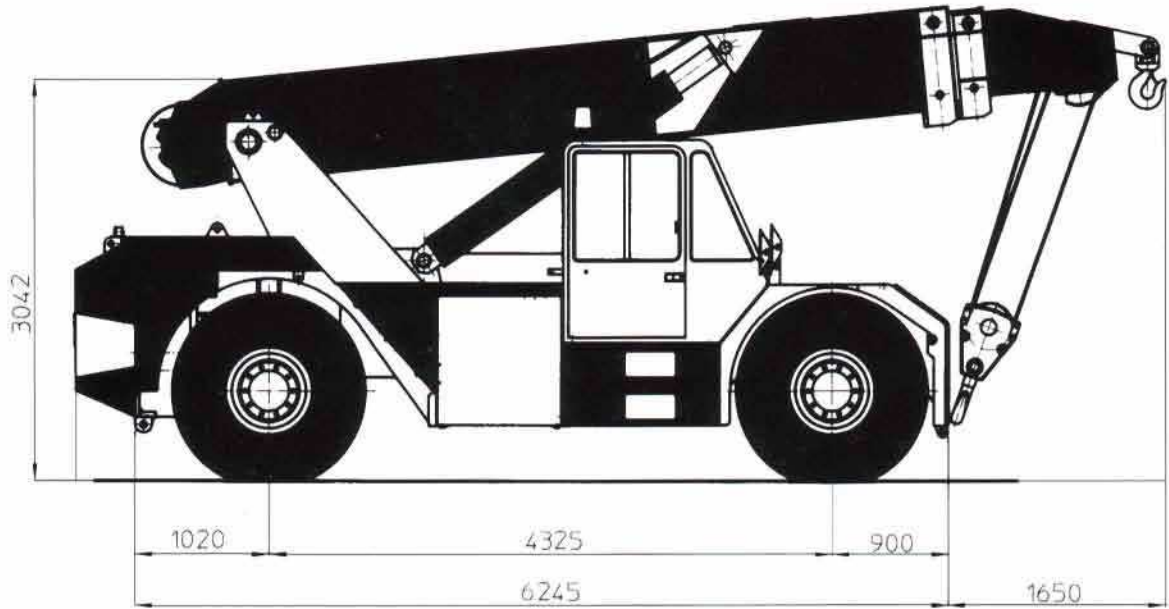

La ORMIG si riserva il diritto di apportare qualsiasi modifica senza preavviso né responsabilità.
ORMIG reserves the right to amend these specifications at any time without notice and responsibility.
ORMIG se réserve le droit de modifier ces spécifications sans préavis ni responsabilité.

Din 15019.2

TABELLA PORTATA JIB A MOVIMENTAZIONE IDRAULICA (TON)
 HIDRAULIC MOTION FLY - JIB LIFTING CAPACITY CHART (TONNES)
 TABLEAU DE CHARGES POUR FLECHETTE HYDRAULIQUE (TONNES)

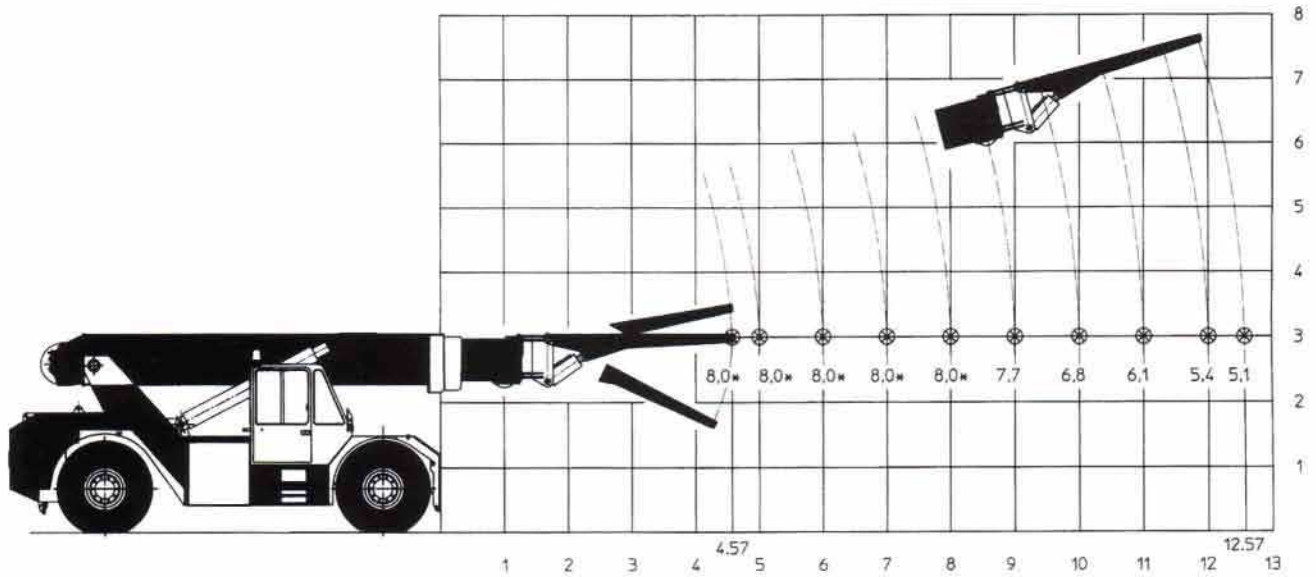

Din 15019.2

TABELLA PORTATA DI SOLLEVAMENTO CON GANCIO FISSO (TON)
 LIFTING CAPACITY CHART WITH FIX HOOK (TONNES)
 TABLEAU DE CHARGES AVEC CROCHET FIXE (TONNES)

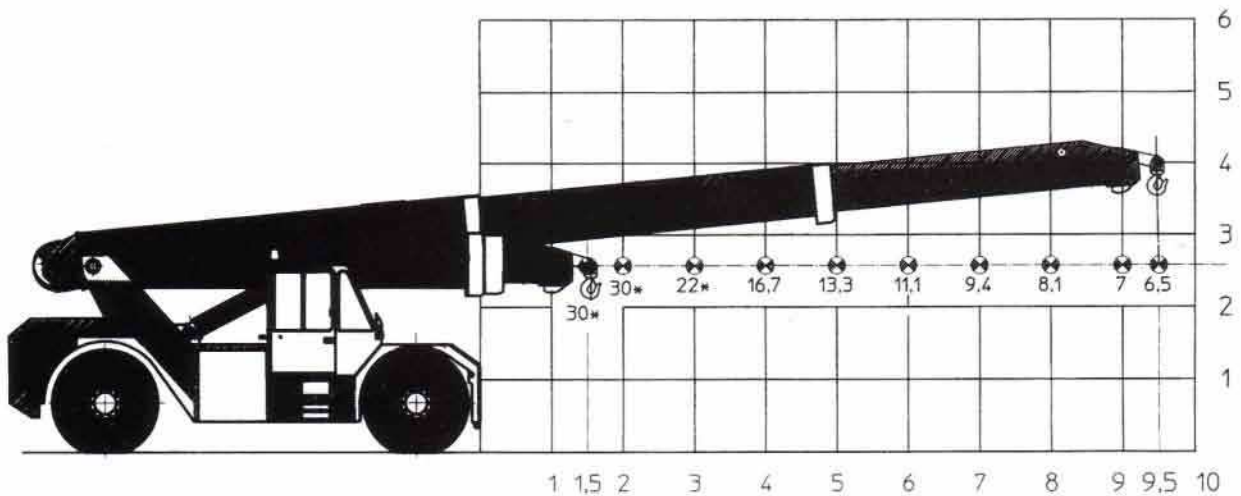

* Portate limitate da fattori diversi dal ribaltamento
 * Capacities determined by factors other than tipping load
 * Charges déterminées par des facteurs autres que le basculement

Din 15019.2

TABELLA PORTATA DI SOLLEVAMENTO (TON) LIFTING CAPACITY CHART (TONNES) TABLEAU DE CHARGES (TONNES)

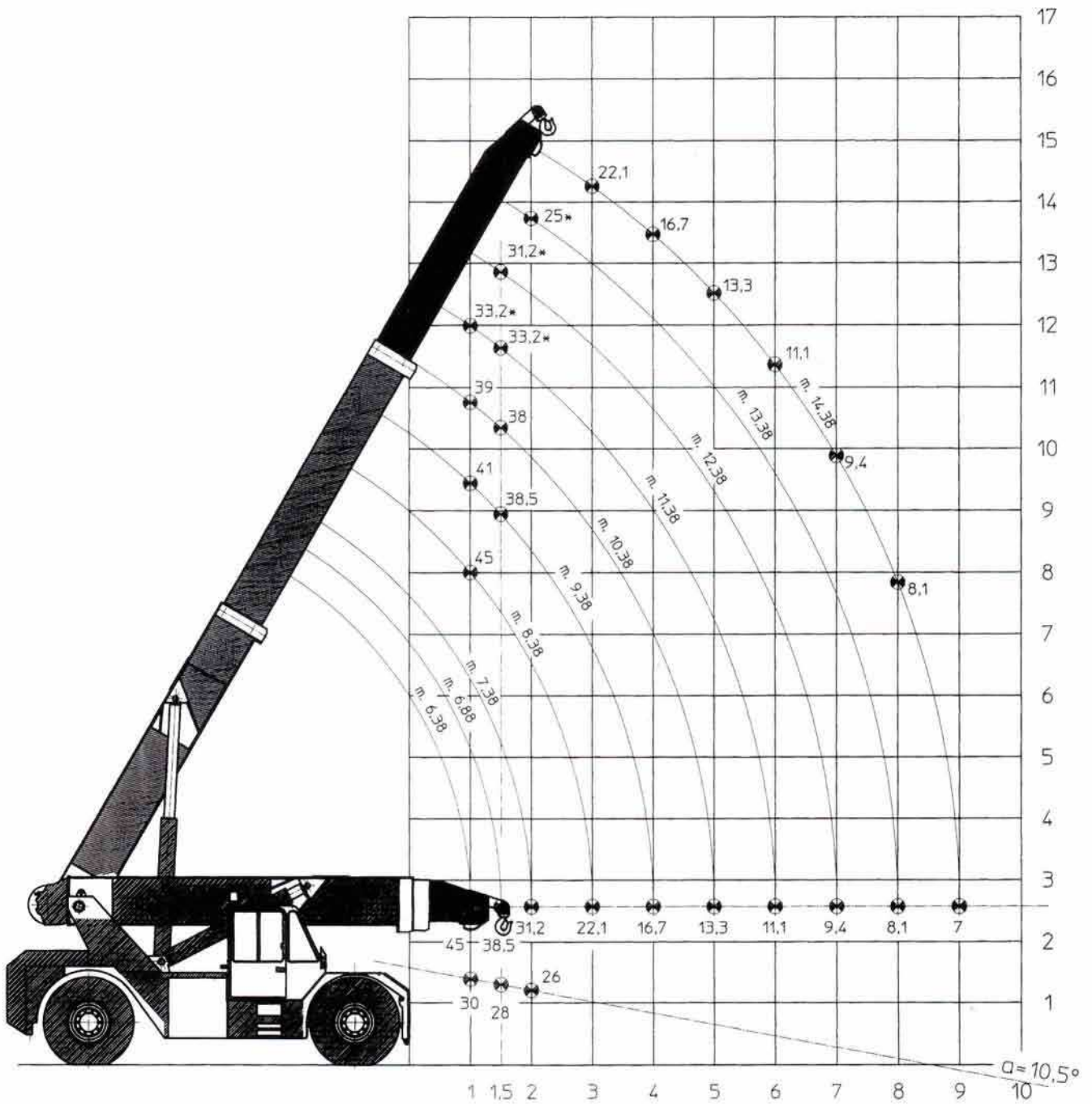

* Portate limitate da fattori diversi dal ribaltamento
 * Capacities determined by factors other than tipping load
 * Charges déterminées par des facteurs autres que le basculement

autovictor

 *Keep on moving to the future.*

MANUALE TECNICO ORMIG 45 TM

AUTOVICTOR s.r.l.

Via Galvani 11/13

28060 San Pietro Mosezzo - Novara

Tel. +39 0321 35000

info@autovictor.it

www.autovictor.it